

Predicting Cryptocurrency Price Using RNN and LSTM Method

Dzaki Mahadika Gunarto ^[1], Siti Sa'adah ^[2], Dody Qori Utama ^[3]

School of Computing ^{[1],[2],[3]}

Telkom University

Bandung, Indonesia

dzakimahadika@hotmail.com ^[1], sitisaadah@telkomuniversity.ac.id ^[2], dodyqori@telkomuniversity.ac.id ^[3]

Abstract— Cryptocurrency price prediction is a crucial task for financial investors as it helps determine appropriate investment strategies and mitigate risk. In recent years, deep learning methods have shown promise in predicting time-series data, making them a viable approach for cryptocurrency price prediction. In this study, we compare the effectiveness of two deep learning techniques, the Recurrent Neural Network (RNN) and Long-Short Term Memory (LSTM), in predicting the prices of Bitcoin and Ethereum. Results of this research show that the LSTM method outperformed the RNN method, obtaining lower Root Mean Squared Error (RMSE) and Mean Absolute Percentage Error (MAPE) values for predicting both cryptocurrencies. Bitcoin and Ethereum. Specifically, the LSTM model had a RMSE of 0.061 and MAPE of 5.66% for predicting Bitcoin, and a RMSE of 0.036 and MAPE of 4.58% for predicting Ethereum. In this research, we found that the LSTM model is a more effective method for predicting cryptocurrency prices than the RNN model.

Keywords— *Cryptocurrency, RNN, LSTM, RMSE, MAPE*

Abstrak— Prediksi harga cryptocurrency merupakan tugas yang sangat penting bagi investor keuangan karena dapat membantu menentukan strategi investasi yang sesuai dan mengurangi risiko. Dalam beberapa tahun terakhir, metode deep learning telah menunjukkan potensi dalam memprediksi data time-series, sehingga menjadi metode yang layak untuk prediksi harga cryptocurrency. Dalam studi ini, kami membandingkan efektivitas dua teknik deep learning, yaitu Recurrent Neural Network (RNN) dan Long-Short Term Memory (LSTM), dalam memprediksi harga Bitcoin dan Ethereum. Hasil penelitian ini menunjukkan bahwa metode LSTM lebih unggul dibanding metode RNN, dengan nilai Root Mean Squared Error (RMSE) dan Mean Absolute Percentage Error (MAPE) yang lebih rendah untuk memprediksi kedua cryptocurrency tersebut. Bitcoin dan Ethereum. Secara spesifik, model LSTM memiliki nilai RMSE sebesar 0,061 dan MAPE sebesar 5,66% untuk memprediksi Bitcoin, serta nilai RMSE sebesar 0,036 dan MAPE sebesar 4,58% untuk memprediksi Ethereum. Dalam penelitian ini, kami menemukan bahwa model LSTM merupakan metode yang lebih efektif untuk memprediksi harga cryptocurrency dibanding model RNN.

Kata Kunci— *Cryptocurrency, RNN, LSTM, RMSE, MAPE*

I. INTRODUCTION

Cryptocurrencies are digital or virtual currencies that are used to exchange and transfer assets digitally. They use cryptography to ensure the secure transfer of assets, to regulate the creation of new cryptocurrencies, and to protect the integrity of transactions [1], [2]. This blockchain-based digital currencies have experienced significant fluctuations in value in recent years [3]. Cryptocurrency tokens, which are based on blockchain technology, can represent a variety of physical and non-physical assets, such as financial instruments, stocks, and bonds. They have been widely adopted in various fields. A key aspect of studying the behavior of cryptocurrency tokens is the ability to model and forecast their pricing [4]. An essential component of researching the behavior of cryptocurrency tokens is the modeling and prediction of their prices [5].

In recent years, deep learning techniques have been applied to time-series prediction problems in various fields, including the cryptocurrency market [6]–[10]. These methods have been shown to be effective in improving the accuracy of time-series predictions in real-world applications. For example, in a study by [11], the Autoregressive Integrated Moving Average (ARIMA) model was used to forecast the future values of Bitcoin prices in R programming language. The results of this study showed that the mean error was less than 6% for most values. In another study, [12] used a Long Short-Term Memory Recurrent Neural Network (LSTM-RNN) model to predict the price of Bitcoin. The LSTM-RNN model was found to perform better than a traditional neural network model, and the RMSE was 0.14. Recent research on time-series prediction using RNN and LSTM networks has shown promising results in a variety of applications. However, a gap in the literature is the lack of direct comparison between the performance of RNN and LSTM methods on the same task. Many studies have employed one method or the other, but a comprehensive analysis of how these two types of models compare in terms of accuracy and computational efficiency has yet to be conducted.

Based on the research that has been discussed previously, this research will focus on measuring how good RNN and LSTM to predict cryptocurrencies prices and comparing between both methods by measuring evaluation metrics of each of the method. The dataset used in this research is two cryptocurrency datasets taken from the Kaggle page which is Bitcoin daily price and Ethereum daily price from August 8,

2015 until July 6, 2021 [13]. RNN that is used in this research is Simple RNN, while LSTM that is used is the default LSTM. Both methods are able to capture the sequential information and internal characteristics of the trajectories, which is useful for predicting future values [14]. The evaluation metrics of both systems will be measured by using RMSE and MAPE.

II. METHODOLOGY

In this study, we aim to predict the future price of cryptocurrency using RNN and LSTM models. To do this, we first collected a dataset of historical cryptocurrency price data from Kaggle page which is Bitcoin and Ethereum daily price [13]. And then after that we pre-processed the data by performing normalization. Next, we split the pre-processed data into 80% training data and 20% testing data. We trained RNN and LSTM models on the training data and evaluated their performance on the testing data. We compared the performance of the two models using various evaluation metrics, which are MAPE and RMSE. Finally, we used the best-performing model to make price predictions on unseen data by using RNN and LSTM models to accurately predict cryptocurrency prices, evaluating both models with MAPE and RMSE, and then comparing both MAPE and RMSE value from each model. Fig. 1 shows the flowchart of the proposed research.

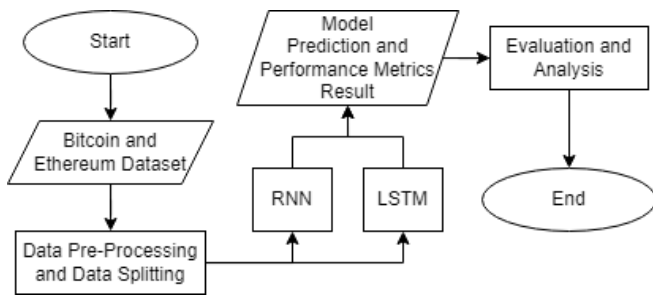

Fig. 1. Flowchart of Proposed Research

A. Dataset

The dataset that has been collected is data from Kaggle in [13], which refers to the data of Bitcoin and Ethereum price history. The dataset that is taken from Kaggle is dataset that consist of Bitcoin price with 2991 daily data from April 29, 2013 until July 6, 2021 and Ethereum Price with 2160 daily data from August 8, 2015 until July 6, 2021. Dataset that used in this research is Bitcoin daily price and Ethereum daily price from August 8, 2015 until July 6, 2021 with 2160 daily data of both cryptocurrencies. The original dataset contains 10 attributes, which are SNo, Name, Symbol, Date, High, Low, Open, Close, Volume, Marketcap.

TABLE I. BITCOIN DATASET SAMPLE

SNo	Name	Symbol	Date	High	Low	Open	Close	Volume	Market
-----	------	--------	------	------	-----	------	-------	--------	--------

		i							cap
1	Bitcoin	BTC	8/8/2015 23:59	279.92 8009	260.70 99915	279.74 20044	260.99 70093	585330 00	377804 9024
2	Bitcoin	BTC	8/9/2015 23:59	267.00 29907	260.46 79871	261.11 59973	265.08 30078	237896 00	383813 0130
3	Bitcoin	BTC	8/10/2015 23:59	267.03 20129	262.59 60083	265.47 79968	264.47 00012	209794 00	383035 2069
4	Bitcoin	BTC	8/11/2015 23:59	270.38 59863	264.09 39941	264.34 20105	270.38 59863	254339 00	391714 2819
5	Bitcoin	BTC	8/12/2015 23:59	270.67 30042	265.46 89941	270.59 79919	266.37 60071	268154 00	385988 8131

TABLE II. ETHEREUM DATASET SAMPLE

SNo	Name	Symbol	Date	High	Low	Open	Close	Volume	Market
1	Ethereum	ETH	8/8/2015 23:59	2.7988 10005	0.7147 25018	2.7937 60061	0.753324 986	67418 8	454868 94.24
2	Ethereum	ETH	8/9/2015 23:59	0.8798 09976	0.6291 90981	0.7061 35988	0.701897 025	53217 0	423995 73.5
3	Ethereum	ETH	8/10/2015 23:59	0.7298 53988	0.6365 46016	0.7139 89019	0.708447 993	40528 3	428183 64.39
4	Ethereum	ETH	8/11/2015 23:59	1.1314 10003	0.6632 35009	0.7080 87027	1.067860 007	14631 00	645692 88.43
5	Ethereum	ETH	8/12/2015 23:59	1.2899 4	0.8836 07984	1.0587 50033	1.217440 009	21506 20	736450 10.99

Table I shows five data sample of Bitcoin dataset while Table II shows five data sample of Ethereum dataset, both cryptocurrency dataset includes "Date" column which is the date of observation, "SNo" column which is number of daily data, "Open" column for the opening price on that day, "High" column for the highest price on that day, "Low" column for the lowest price on that day, "Close" column for the closing price on that day, "Volume" the volume of transactions on that day, and "Marketcap" column for the market capitalization in US dollars.

B. Recurrent Neural Network (RNN)

RNN are a class of artificial neural networks that are designed to analyze sequential data. These networks are able to maintain an internal state, or memory, which enables them to exhibit temporal dynamic behaviors. RNNs have been widely employed in a variety of applications, including handwriting recognition, speech recognition, and time-series prediction. One of the key advantages of RNNs is their ability to identify patterns within sequences of input data [15]. In this research, we use simple RNN for predicting price of the cryptocurrency. Fig. 2 shows the architecture of simple RNN.

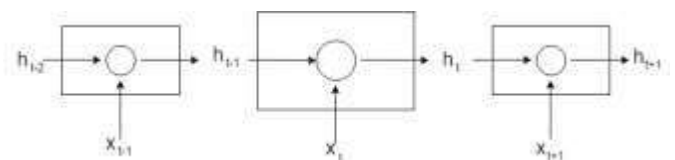

Fig. 2. Architecture of Simple RNN

A simple RNN is essentially a group of individual neural

networks that are connected together, with each network transmitting a message to the next. In other words, these networks have a short-term memory that stores knowledge about the data they have seen, but they are unable to maintain long-term time series information [16]. A simple RNN equation is shown in (1):

$$h_t = g(Wx_t + U_f h_{t-1} + b) \quad (1)$$

From equation above, $g(x)$ represents an activation function, the hyperbolic tangent function, $g(x) = \tanh(x)$ is usually used as the activation function. U and W are weight matrices that can be adjusted for the h layer, b is a bias, and x is an input vector.

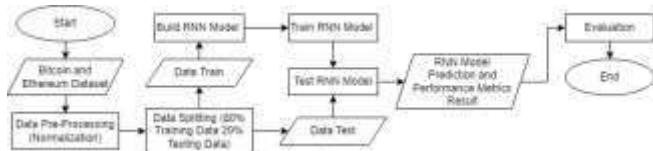

Fig. 3. RNN Flowchart of Proposed Research

Fig. 3 shows the RNN flowchart of this research, first we start with collecting daily price data of Bitcoin and Ethereum from Kaggle [13] After that, the next thing to do is pre-processing the data by performing normalization. After normalization has been done, we split the data into 80% training data and 20% testing data. Next, we build an RNN model and also train the RNN model with the training data that has been split before. We evaluated the RNN model performance on the testing data, then the prediction results and evaluation metrics of RNN model will appear, model evaluation metrics that is used in this research is MAPE and RMSE. At the end, we analyze our RNN model result and performance.

C. Long Short-Term Memory (LSTM)

The LSTM model is an advanced recurrent neural network that is specifically designed to tackle the problems of exploding and vanishing gradients that often occur when learning long-term dependencies, even when the minimum time lags are very long. This makes the LSTM model particularly effective for handling data with complex temporal dependencies [17]. In the case of an LSTM architecture, the traditional hidden layers are replaced with LSTM cells. These cells contain various gates that control the flow of input data.

An LSTM cell is composed of an input gate, cell state, forget gate, and output gate, as well as a sigmoid layer, tanh layer, and pointwise multiplication operation. The input gate receives input, the cell state passes through the entire network and can add or remove information with the help of the gates, the forget gate determines which fraction of the information should be allowed, and the output gate produces the output generated by the LSTM. The sigmoid layer generates numbers between 0 and 1 that indicate how much of each component should be allowed through, while the tanh layer generates a new vector that is added to the state. The cell state is updated based on the outputs from the gates, and this process is mathematically represented by certain equations [18].

In summary, the LSTM architecture is composed of memory blocks that are connected in a recurrent manner. These blocks are designed to maintain their state over time and control the flow of information through non-linear gating units [19]. The objective of this section is describing the mechanisms behind the LSTM model. Consider a network with N processing blocks and M inputs. The forward pass of this recurrent neural network can be described as follows. The LSTM architecture will be shown in Fig. 4.

The block input step involves combining the current input $x^{(t)}$ with the output of the previous LSTM unit $y^{(t-1)}$ to update the block input component. This is accomplished through the following equation:

$$z^{(t)} = g(W_z x^{(t)} + R_z y^{(t-1)} + b_z) \quad (2)$$

This equation describes the process of combining the current input, $x^{(t)}$, and the output of the previous iteration, $y^{(t-1)}$, in order to update the block input component. The weights associated with $x^{(t)}$ and $y^{(t-1)}$ are represented by W_z and R_z , respectively, while the bias weight vector is represented by b_z .

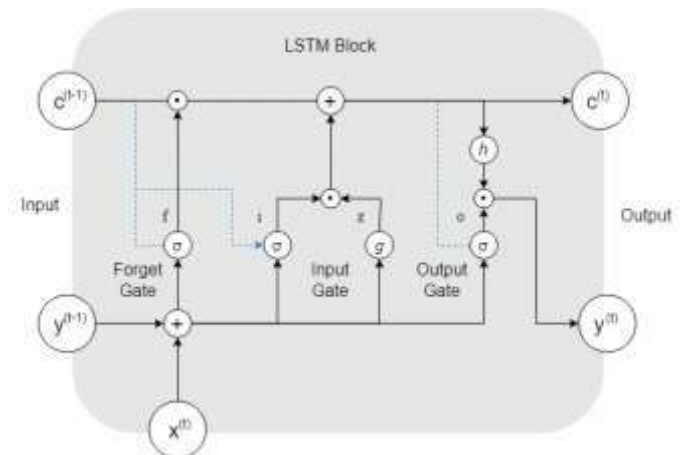

Fig. 4. Architecture of LSTM

The input gate in the LSTM model combines the current input $x^{(t)}$, the output of the previous LSTM unit $y^{(t-1)}$, and the cell value $c^{(t-1)}$ from the previous iteration. This step updates the input gate using the following equation:

$$i^{(t)} = \sigma(W_i x^{(t)} + R_i y^{(t-1)} + p_i \odot c^{(t-1)} + b_i) \quad (3)$$

In this equation, \odot represents the point-wise multiplication of two vectors. W_i , R_i , and p_i are the weights associated with the current input $x^{(t)}$, the previous output $y^{(t-1)}$, and the previous cell state $c^{(t-1)}$, respectively. The bias vector b_i is also a part of this component. In the previous step, LSTM layer determines which information should be kept in the cell states $c^{(t)}$ of the network. This process involves choosing the candidate values $z^{(t)}$ that may be added to the cell states and determining the activation values $i^{(t)}$ of the input gates.

In forget gate, the LSTM unit determines which information should be removed from the previous cell states $c^{(t-1)}$. The activation values $f^{(t)}$ of the forget gates at time step t are calculated using the current input $x^{(t)}$, the previous output $y^{(t-1)}$, the previous cell state $c^{(t-1)}$, the peephole connections, and the bias terms b_f of the forget gates. This calculation is performed to determine which information should be discarded from the previous cell states.

$$f^{(t)} = \sigma(W_f x^{(t)} + R_f y^{(t-1)} + p_f \odot c^{(t-1)} + b_f) \quad (4)$$

From the equation above, W_f , R_f , and p_f are the weights associated with the current input $x^{(t)}$, the previous output $y^{(t-1)}$, and the previous cell state $c^{(t-1)}$, respectively. The bias weight vector b_f is also a part of this component.

For LSTM cell, the cell value is calculated by combining the block input $z^{(t)}$, the input gate values $i^{(t)}$, and the forget gate values $f^{(t)}$ with the previous cell value. This process is depicted in the following equation.

$$c^{(t)} = z^{(t)} \odot i^{(t)} + c^{(t-1)} \odot f^{(t)} \quad (5)$$

In output gate, the output gate is calculated by combining the current input $x^{(t)}$, the previous output of the LSTM unit $y^{(t-1)}$, and the previous cell value $c^{(t-1)}$. This calculation is depicted in the following equation.

$$o^{(t)} = \sigma(W_o x^{(t)} + R_o y^{(t-1)} + p_o \odot c^{(t-1)} + b_o) \quad (6)$$

In this equation, W_o , R_o , and p_o are the weights associated with the current input x , the previous output y , and the previous cell value $c^{(t-1)}$, respectively. The bias weight vector b_o is also a part of this component.

Finally, the block output is calculated by combining the current cell value $c^{(t)}$ with the current output gate value as follows:

$$y^{(t)} = g(c^{(t)}) \odot o^{(t)} \quad (7)$$

In the previous steps that has been stated, σ , g , and h represent point-wise non-linear activation functions. The logistic sigmoid function $\sigma(x) = \frac{1}{1+e^{1-x}}$ is utilized as the activation function for the gates, and the hyperbolic tangent function $g(x) = h(x) = \tanh(x)$ is frequently used as the activation function for the block input and output.

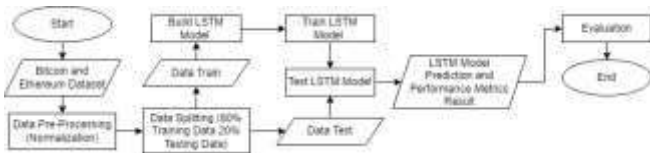

Fig. 5. LSTM Flowchart of Proposed Research

Fig. 5 shows the LSTM flowchart of this research, first we start with collecting daily price data of Bitcoin and Ethereum

from Kaggle [13]. After completing initial steps, the data is pre-processed by normalizing it. Once normalization is finished, the data is split into 80% for training and 20% for testing. An LSTM model is constructed and trained using the previously divided training data. The LSTM model's performance is evaluated using the testing data, and the resulting predictions and evaluation metrics, such as MAPE and RMSE, are analyzed. Finally, the results and performance of the LSTM model are examined.

D. Evaluation Metrics

There are many different evaluation metrics that can be used to assess the accuracy of a predictive model. RMSE and MAPE are two such metrics that are commonly used for this purpose. These metrics involve comparing the original value y_i to the predicted value \hat{y} for each data point and taking the average of these differences over the entire dataset n [20]. RMSE are defined as follows:

$$RMSE = \sqrt{\frac{\sum_{i=1}^n (\hat{y} - y_i)^2}{n}} \quad (8)$$

MAPE is a measure used to assess the accuracy of a prediction. It is calculated by taking the absolute error for each period and dividing it by the observed value for that period, then averaging these percentages. This method is useful when the magnitude of the prediction variable is important in evaluating the accuracy of the prediction. MAPE shows the error in prediction as a percentage of the true value [21]. The MAPE is a commonly used evaluation metric for forecasting accuracy and has several desirable characteristics, including being a reliable and unit-free measure that is easy to interpret and supports statistical evaluation. It is also clear and easy to present, and it uses all of the available information about the error. The formula of MAPE is defined in the equation below.

$$MAPE = \frac{1}{n} \sum_{i=1}^n \frac{|\hat{y} - y_i|}{y_i} \times 100\% \quad (9)$$

MAPE is calculated by finding the absolute difference between the predicted value \hat{y} and the actual value y_i for each time point i in the sample, dividing this difference by the actual value, and then taking the mean of these values across all time points in the sample n [22].

III. RESULT AND ANALYSIS

In this study, we aimed to predict cryptocurrency price using RNN and LSTM models. To evaluate the performance of these models, we used a dataset containing daily historical cryptocurrency prices. We divided the dataset into 80% training set and 20% testing set, and trained the RNN and LSTM models on the training data. After that, we compared the predictions made by the models on the testing data to the actual price movements. At the end, we compared RNN and LSTM evaluation metrics value result for predicting Bitcoin and Ethereum. In this sections, we present and analyze the results of our experiments.

TABLE III. COMBINATION OF USED HYPERPARAMETER

No	Batch Size	Epochs
1	16	100
2	16	200
3	16	400
4	16	600
5	16	800
6	32	100
7	32	200
8	32	400
9	32	600
10	32	800

Table III shows the varied of batch size and epochs that will be trained later by using RNN and LSTM models on the training data for each combination of hyperparameters. We also evaluated the models' performance on the testing data and compared the predictions to the actual price movements. In the following sections, we present and analyze the results of our hyperparameter optimization experiment.

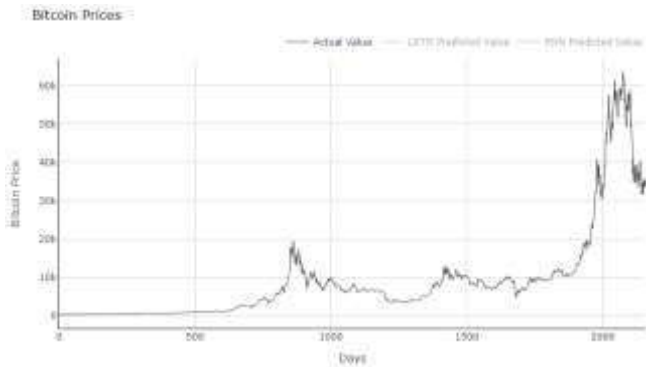

Fig. 6. Bitcoin Daily Data in 2160 days

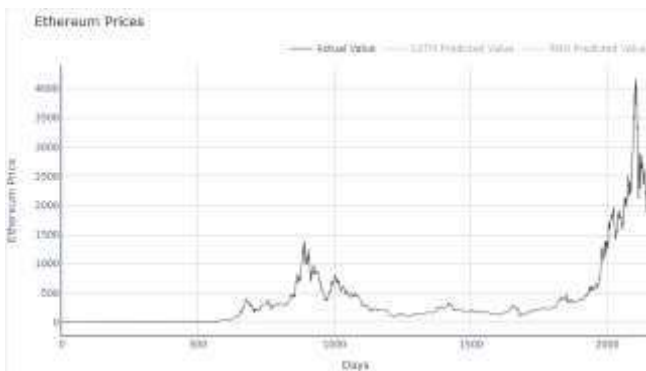

Fig. 7. Ethereum Daily Data in 2160 days

Fig. 6 and Fig. 7 shows Bitcoin and Ethereum daily data in 2160 days starting from August 8, 2015 until July 6, 2021. To determine the optimal hyperparameters for these models and also finding the lowest value of RMSE and MAPE from both methods, we conducted an experiment using dataset containing daily historical Bitcoin and Ethereum prices from Fig. 6 and Fig. 7.

TABLE IV. RMSE AND MAPE RESULT FROM VARIOUS BATCH DATA AND EPOCHS EXPERIMENT WITH BITCOIN DATASET

No	Batch Size	Epochs	Bitcoin Dataset			
			RNN Model		LSTM Model	
			RMSE	MAPE	RMSE	MAPE
1	16	100	0.158	13.95%	0.090	8.05%
2	16	200	0.175	14.93%	0.067	5.94%
3	16	400	0.105	9.01%	0.088	7.66%
4	16	600	0.140	12.20%	0.068	6.12%
5	16	800	0.129	11.00%	0.137	11.57%
6	32	100	0.091	8.10%	0.093	7.82%
7	32	200	0.207	17.80%	0.085	7.70%
8	32	400	0.104	9.08%	0.139	11.92%
9	32	600	0.102	8.82%	0.062	5.66%
10	32	800	0.139	11.74%	0.083	7.23%

TABLE V. RMSE AND MAPE RESULT FROM VARIOUS BATCH DATA AND EPOCHS EXPERIMENT WITH ETHEREUM DATASET

No	Batch Size	Epochs	Ethereum Dataset			
			RNN Model		LSTM Model	
			RMSE	MAPE	RMSE	MAPE
1	16	100	0.078	8.06%	0.081	8.65%
2	16	200	0.070	7.76%	0.041	4.90%
3	16	400	0.048	5.46%	0.051	5.99%
4	16	600	0.045	5.20%	0.046	5.27%
5	16	800	0.060	6.92%	0.043	5.02%
6	32	100	0.115	11.67%	0.038	4.70%
7	32	200	0.107	10.46%	0.103	11.95%
8	32	400	0.065	6.63%	0.054	5.83%
9	32	600	0.062	6.51%	0.036	4.58%
10	32	800	0.051	5.67%	0.044	5.12%

The results of the experiment, which used a dataset of daily historical cryptocurrency prices are presented in Table IV and Table V. These tables reveal that the LSTM model with a batch size of 32 and 600 epochs achieved the lowest values of RMSE and MAPE for predicting Bitcoin, with an RMSE of 0.062 and a MAPE of 5.66%. Similarly, for predicting the price of Ethereum, the LSTM model with a batch size of 32 and 600 epochs had the lowest values of RMSE (0.036) and MAPE (4.58%).



Fig. 8. Actual vs Predicted Value of Bitcoin Price Using RNN in Data Test Set

In Fig. 8, actual value is showed with black color line, and RNN predicted value is showed with red color line. Fig. 8 shows the predicted Bitcoin values compared to the actual values in the test dataset using an RNN model with a batch size of 32 and 600 epochs. The evaluation metrics for this model, used to predict Bitcoin values, resulted in an RMSE of 0.102 and a MAPE of 8.82%. This RNN evaluation models result for predicting Bitcoin will be compared later with the LSTM evaluation models result for predicting the same dataset.

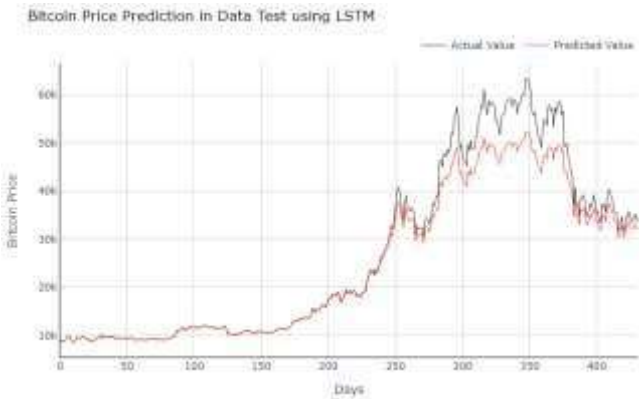

Fig. 9. Actual vs Predicted Value of Bitcoin Price Using LSTM in Data Test Set

In Fig. 9, actual value is showed with black color line, and LSTM predicted value is showed with red color line. Fig. 9 shows the predicted Bitcoin values compared to the actual values in the test dataset using an LSTM model with a batch size of 32 and 600 epochs. The evaluation metrics for this model, used to predict Bitcoin values, resulted in an RMSE of 0.062 and a MAPE of 5.66%. Previously, RNN resulted in an RMSE of 0.102 and a MAPE of 8.82% for predicting Bitcoin with the same batch size and epochs. Therefore, for predicting Bitcoin Price, LSTM achieved the lower value of RMSE and MAPE.

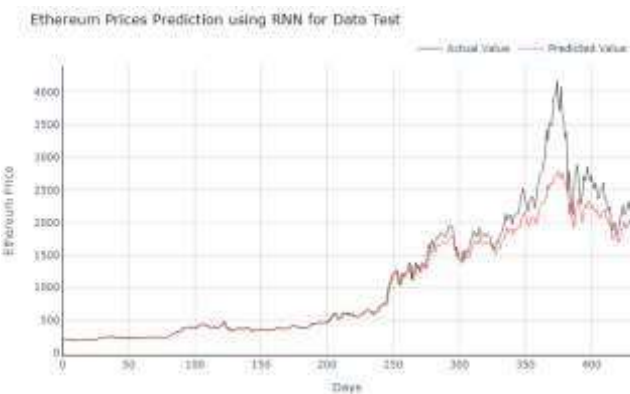

Fig. 10. Actual vs Predicted Value of Ethereum Price Using RNN in Data Test Set

In Fig. 10, actual value is showed with black color line, and RNN predicted value is showed with red color line. Fig. 10 shows the predicted Ethereum values compared to the actual values in the test dataset using an RNN model with a batch size of 32 and 600 epochs. The evaluation metrics for this model, used to predict Ethereum values, resulted in an RMSE of 0.062 and a MAPE of 6.51%. This RNN evaluation models result for predicting Ethereum will be compared later with the LSTM evaluation models result for predicting the same dataset.



Fig. 11. Actual vs Predicted Value of Ethereum Price Using LSTM in Data Test Set

Fig. 11 shows the predicted Ethereum values compared to the actual values in the test dataset using an LSTM model with a batch size of 32 and 600 epochs. The evaluation metrics for this model, used to predict Ethereum values, resulted in an RMSE of 0.036 and a MAPE of 4.58%. In Fig. 11, actual value is showed with black color line, and LSTM predicted value is showed with red color line. Previously, RNN resulted in an RMSE of 0.062 and a MAPE of 6.51% for predicting Ethereum with the same batch size and epochs. Therefore, for predicting Ethereum Price, LSTM once again achieved the lower value of RMSE and MAPE.



Fig. 12. Actual vs Predicted Value of Bitcoin Price Using RNN and LSTM

In Fig. 12, actual value is showed with black color line, RNN predicted value is showed with red color line, and LSTM predicted value is showed with green color line. Fig. 12 shows the predicted Bitcoin values using RNN and LSTM model compared to the actual values for 2160 days with a batch size

of 32 and 600 epochs. This figure shows that the prediction results of LSTM for predicting Bitcoin price in 2160 days is better than RNN since LSTM prediction value obtained more closer result to the actual value than the RNN one.



Fig. 13. Actual vs Predicted Value of Ethereum Price Using RNN and LSTM

In Fig. 13, actual value is showed with black color line, RNN predicted value is showed with red color line, and LSTM predicted value is showed with green color line. Fig. 13 shows the predicted Ethereum values using RNN and LSTM model compared to the actual values for 2160 days with a batch size of 32 and 600 epochs. This figure also shows that the prediction results of LSTM for predicting Ethereum price in 2160 days is better than RNN since LSTM prediction value obtained more closer result to the actual value than the RNN one.

Based on the experiment that has been done with Bitcoin and Ethereum dataset, we found that the LSTM model is a better model for predicting Bitcoin and Ethereum price rather than RNN model. The RNN model was not able to outperform the lowest values of RMSE and MAPE achieved by the LSTM model, even with the most optimal hyperparameters. The best RMSE and MAPE results of RNN model is from batch size of 32 and 100 epochs, with RMSE value of 0.091 and MAPE value of 8.10% for predicting Bitcoin and from batch size of 16 and 600 epochs, with RMSE value of 0.045 and MAPE value of 5.20% for predicting Ethereum. While the best LSTM model had a RMSE of 0.061 and MAPE of 5.66% for predicting Bitcoin, and a RMSE of 0.036 and MAPE of 4.58% for predicting Ethereum with batch size of 32 and 600 epochs for predicting both cryptocurrencies.

IV. CONCLUSION

In this research, two different models of deep learning techniques have been constructed and applied to the real dataset to predict the prices of two cryptocurrencies, which are Bitcoin and Ethereum. RMSE and MAPE were calculated for RNN and LSTM in predicting both cryptocurrencies to measure the accuracy of the models. After comparing evaluation metrics results of both models, this research indicated that LSTM model is a better model for predicting Bitcoin and Ethereum price rather than RNN model with the lowest RMSE value 0.061 and MAPE value 5.66% for predicting Bitcoin, and a RMSE value 0.036 and MAPE value 4.58% for predicting Ethereum with batch size of 32 and 600 epochs for predicting both cryptocurrencies. The hyperparameters of the models also had an impact on the prediction results. These findings suggest that LSTM may be a useful model for predicting cryptocurrency prices and the choice of hyperparameters is an important factor to consider in model construction because it can optimize the model's prediction accuracy result.

In recent years, cryptocurrency has become an increasingly popular topic of interest, with many studies focused on predicting the prices of different cryptocurrencies. The use of RNN and LSTM networks for this purpose has shown promising results. However, there is still much room for further research in this area. Furthermore, comparing the performance of RNN and LSTM on other time-series domain, such as stock prices, weather forecasting, and energy consumption can be beneficial in terms of understanding the generalization ability of the model. Overall, there is still much to be explored in the use of RNNs and LSTMs for cryptocurrency prediction and the results of such research can have significant impact in the field of finance and investment.

REFERENCES

- [1] A. M. Khedr, I. Arif, P. v. Pravija Raj, M. El-Bannany, S. M. Alhashmi, and M. Sreedharan, "Cryptocurrency price prediction using traditional statistical and machine-learning techniques: A survey," *Intelligent Systems in Accounting, Finance and Management*, vol. 28, no. 1. John Wiley and Sons Inc, pp. 3–34, Jan. 01, 2021, doi: 10.1002/isaf.1488.
- [2] D. Garcia, C. J. Tessone, P. Mavrodiev, and N. Perony, "The digital traces of bubbles: Feedback cycles between socio-economic signals in the Bitcoin economy," *J R Soc Interface*, vol. 11, no. 99, Oct. 2014, doi: 10.1098/rsif.2014.0623.
- [3] M. Saad, J. Choi, D. Nyang, J. Kim, and A. Mohaisen, "Toward characterizing blockchain-based cryptocurrencies for highly accurate predictions," *IEEE Syst J*, vol. 14, no. 1, pp. 321–332, Mar. 2020, doi: 10.1109/JSYST.2019.2927707.
- [4] J. Mattila, "ETLA Working Papers The Disruptive Potential of Distributed Consensus Architectures," 2016, [Online]. Available: <http://pub.etla.fi/ETLA-Working-Papers-38.pdf>
- [5] Y. Chen and H. K. T. Ng, "Deep learning ethereum token price prediction with network motif analysis," in *IEEE International Conference on Data Mining Workshops, ICDMW*, Nov. 2019, vol. 2019-November, pp. 232–237. doi: 10.1109/ICDMW.2019.00043.
- [6] R. Wan, S. Mei, J. Wang, M. Liu, and F. Yang, "Multivariate temporal convolutional network: A deep neural networks approach for multivariate time series forecasting," *Electronics (Switzerland)*, vol. 8, no. 8, Aug. 2019, doi: 10.3390/electronics8080876.
- [7] T. Y. Kim and S. B. Cho, "Predicting residential energy consumption using CNN-LSTM neural networks," *Energy*, vol. 182, pp. 72–81, Sep. 2019, doi: 10.1016/j.energy.2019.05.230.
- [8] H. Xie, L. Zhang, and C. P. Lim, "Evolving CNN-LSTM Models for Time Series Prediction Using Enhanced Grey Wolf Optimizer," *IEEE*

- Access, vol. 8, pp. 161519–161541, 2020, doi: 10.1109/ACCESS.2020.3021527.
- [9] I. E. Livieris, E. Pintelas, and P. Pintelas, “A CNN–LSTM model for gold price time-series forecasting,” *Neural Comput Appl*, vol. 32, no. 23, pp. 17351–17360, Dec. 2020, doi: 10.1007/s00521-020-04867-x.
- [10] W. Lu, J. Li, J. Wang, and L. Qin, “A CNN-BiLSTM-AM method for stock price prediction,” *Neural Computing and Applications*, vol. 33, no. 10. Springer Science and Business Media Deutschland GmbH, pp. 4741–4753, May 01, 2021, doi: 10.1007/s00521-020-05532-z.
- [11] Francis Xavier Engineering College and Institute of Electrical and Electronics Engineers, *Proceedings of the International Conference on Smart Systems and Inventive Technology (ICSSIT 2018) : Francis Xavier Engineering College, Tirunelveli, India, date: December 13-14, 2018*.
- [12] N. Ghaniaviyanto Ramadhan, N. Annisa Ferani Tanjung, and F. Dharma Adhinata, “Implementation of LSTM-RNN for Bitcoin Prediction”, doi: 10.34818/indojc.2021.6.3.592.
- [13] S. Kumar, “Cryptocurrency Historical Prices Version 3,” *Version 3*, 2021. <https://www.kaggle.com/datasets/sudalairajkumar/cryptocurrencypricehistory>
- [14] J. Li, S. Wang, S. Qin, X. Li, and S. Wang, Eds., *Advanced Data Mining and Applications*, vol. 11888. Cham: Springer International Publishing, 2019. doi: 10.1007/978-3-030-35231-8.
- [15] Z. C. Lipton, J. Berkowitz, and C. Elkan, “A Critical Review of Recurrent Neural Networks for Sequence Learning,” May 2015, [Online]. Available: <http://arxiv.org/abs/1506.00019>
- [16] H. Apaydin, H. Feizi, M. T. Sattari, M. S. Colak, S. Shamshirband, and K. W. Chau, “Comparative analysis of recurrent neural network architectures for reservoir inflow forecasting,” *Water (Switzerland)*, vol. 12, no. 5, May 2020, doi: 10.3390/w12051500.
- [17] S. Hochreiter and J. S. Schmidhuber, “Long Short-Term Memory.”
- [18] IEEE Communications Society and Institute of Electrical and Electronics Engineers, *2017 International Conference on Advances in Computing, Communications and Informatics (ICACCI) : 13-16 Sept. 2017*.
- [19] G. van Houdt, C. Mosquera, and G. Nápoles, “A review on the long short-term memory model,” *Artif Intell Rev*, vol. 53, no. 8, pp. 5929–5955, Dec. 2020, doi: 10.1007/s10462-020-09838-1.
- [20] M. A. Istiaque Sunny, M. M. S. Maswood, and A. G. Alharbi, “Deep Learning-Based Stock Price Prediction Using LSTM and Bi-Directional LSTM Model,” in *2nd Novel Intelligent and Leading Emerging Sciences Conference, NILES 2020*, Oct. 2020, pp. 87–92. doi: 10.1109/NILES50944.2020.9257950.
- [21] U. Khair, H. Fahmi, S. al Hakim, and R. Rahim, “Forecasting Error Calculation with Mean Absolute Deviation and Mean Absolute Percentage Error,” in *Journal of Physics: Conference Series*, Dec. 2017, vol. 930, no. 1. doi: 10.1088/1742-6596/930/1/012002.
- [22] J. J. Montañó Moreno, A. Palmer Pol, A. Sesé Abad, and B. Cajal Blasco, “El índice R-MAPE como medida resistente del ajuste en la previsión,” *Psicothema*, vol. 25, no. 4, pp. 500–506, 2013, doi: 10.7334/psicothema2013.23.